

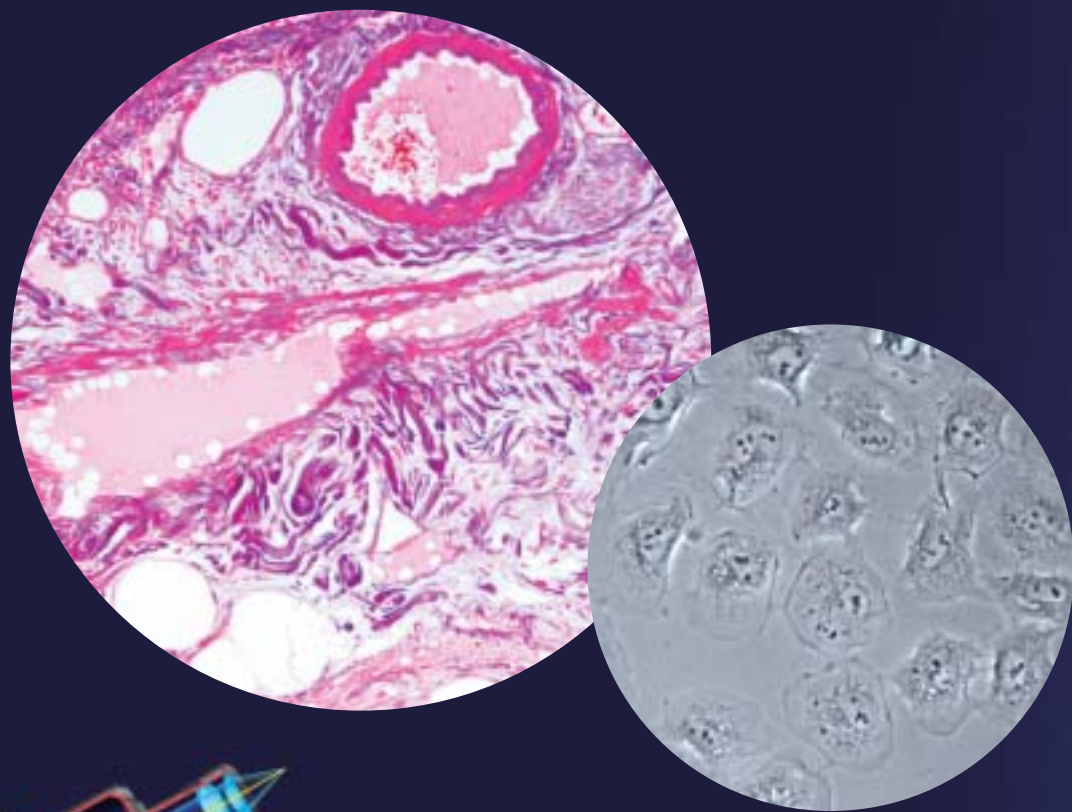

Biological Microscope ECLIPSE E100



E100



ECLIPSE E100

Nikon's CFI optical system and new dedicated objectives produce high quality images.

Nikon, the global leader in advanced optical technology, designed the new infinity corrected microscope to provide outstanding optical performance with elegant ergonomic touches. With a very small footprint, the Eclipse E100 fits easily into the minimum storage space. Its revolutionary CFI* optics achieve flat and sharp images right up to the periphery of the viewfield. Allowing phase contrast observations as well as brightfield, the Eclipse E100 is the perfect choice for education and routine laboratory use.

*Chromatic-aberration Free Infinity

Newly developed objective lenses for flat images

Nikon has developed the new CFI BE Plan objectives, which feature superior image flatness, exclusively for the E100. Chromatic aberration and field curvature are corrected over the entire field of view. Images are clear and bright at every magnification. The E100 provides first class optical quality at a modest price.

Anti-mold design

Anti-mold paint and an anti-mold tablet are used in the objective lenses, eyepiece lenses and eyepiece tubes to prevent mold forming in high-humidity environments.

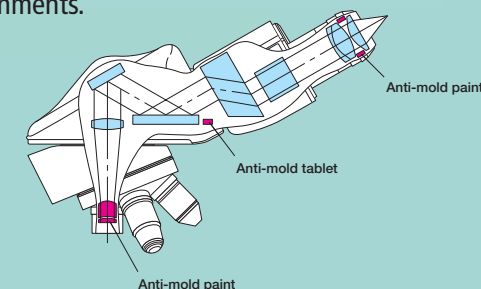



Compact, lightweight body with enhanced operability—providing ease of use



Binocular and trinocular eyepiece tubes available

The Eclipse E100 employs a Siedentopf-type eyepiece tube that provides a constant and accurate eyepiece tube length. Both binocular and trinocular eyepiece tubes are available. A digital camera can be attached to the trinocular eyepiece tube.



Observation with comfort

The eyepiece tube is inclined at 30°, allowing comfortable viewing in a natural posture. By simply swinging the front part of the eyepiece tube, the user can adjust the eyepoint height by up to 34mm to find the most comfortable height for observation. In addition, the interpupillary distance adjustment and the diopter adjustment ring are designed to accommodate a wide range of operators.

Smooth rotation quadruple nosepiece

The high-quality revolving nosepiece has a superior internal detent click-stop mechanism. A knurled elastic covered grip around the base of the nosepiece makes the nosepiece easy to rotate and eliminates the need to touch the objectives.

Double-plate mechanical stage

The built-in stage has a double-plate mechanism with an XY dual travel control. The large, flat stage surface facilitates easy specimen handling. Because the height of the X-axis guide rail is level with the stage surface and the stage surface is flat and smooth, glass slides move easily over the surface. A spring-loaded slide holder is included.



Condenser with position guide markings

The condenser comes with an aperture diaphragm with position guide markings for the 4x, 10x, 40x, 60x and 100x objectives to make operations quick and easy, ensuring perfect specimen images.



Coaxial coarse/fine focus knob

The coaxial coarse/fine focus knob is comfortably located at desk-height level. The focus knob and the stage handle are ergonomically designed and are located equidistant from the operator, meaning they can both be easily adjusted from a normal sitting position. In addition, the torque of the coarse focus knob can be adjusted.

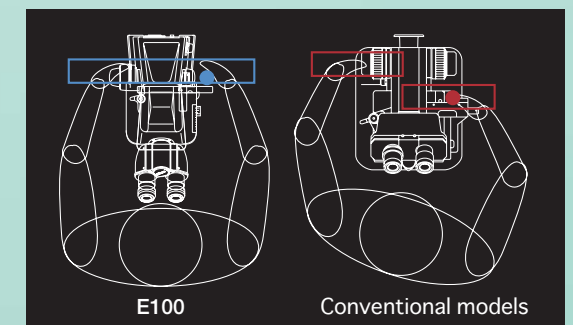

Comparison of the positions of the stage handle and focus control knob

Easy-to-replace halogen lamp

The powerful long life 6V-20W halogen lamp is adjustable up to 6V for convenient illumination control. Replacing the lamp is easy and trouble-free. Simply detach the FL (field lens) unit and replace.



Convenient for transportation and storage

The microscope body is compact and lightweight. A cord hanger and storage case are available to make transporting and storing the E100 easier.



Accessories corresponding to a wide variety of applications

Phase contrast attachment

Simple phase contrast observation at 10x and 40x is possible with a single phase annulus slider. The aperture diaphragm automatically opens when the slider is inserted into the condenser. A phase contrast 100x slider and darkfield ring stop for 10x, 20x or 40x objectives are available as options.

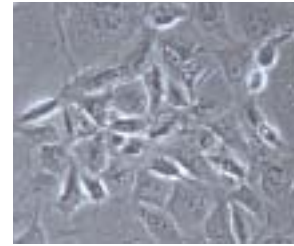

Mirror unit

A mirror unit is available for observation where there is no access to a power source. Removal of the FL (field lens) unit and insertion of the mirror unit in its place is easy.



Eyepiece tube

Siedentopf-type binocular and trinocular eyepiece tubes are available. A digital camera can be attached to the trinocular eyepiece tube.



Condenser

An abbe condenser for brightfield observation and a phase condenser for phase contrast and darkfield observations are available.



Cord hanger

The power cord can be simply wound up when not in use.



Storage case

Available in both wood and aluminum, the dedicated storage case is handy for transporting and storing the E100.



Digital Sight series digital camera system for microscopes

When the trinocular eyepiece tube is used, a digital camera can be attached. The DS-2Mv-L2, a color camera head combined with a standalone control unit, enables focusing and viewing of images on the built-in 8.4-in. LCD monitor without the need for a PC. The optimum imaging conditions that match the observation technique in use can be automatically set by clicking on the appropriate "scene mode." Storing optimal images is easy.

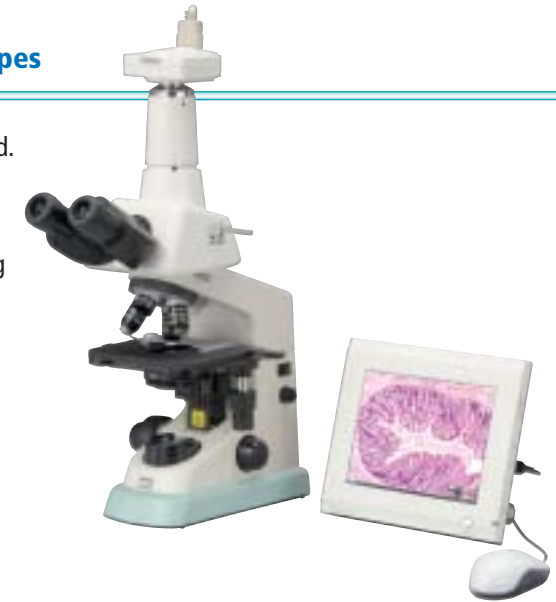

System Diagram

System Diagram

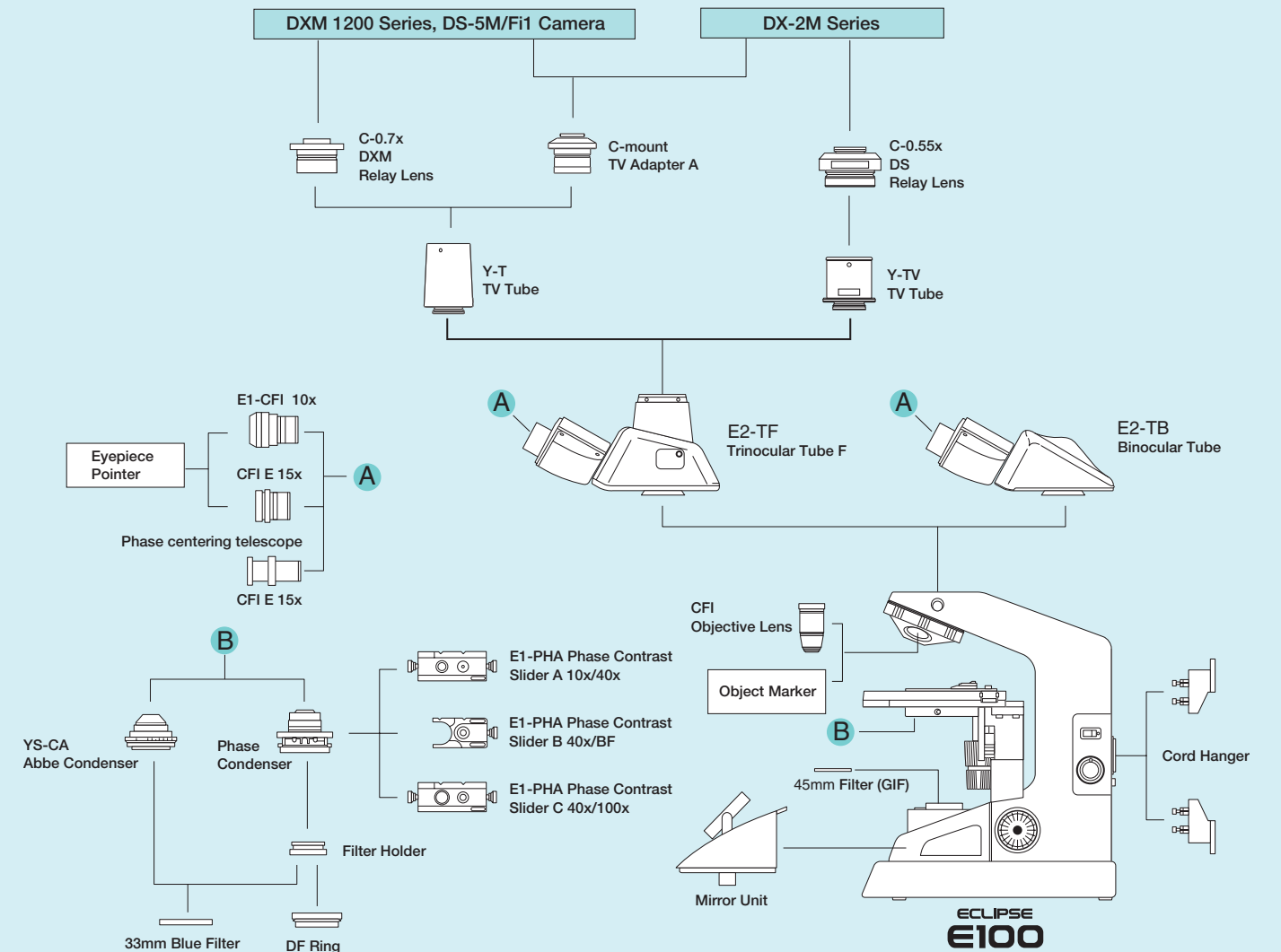

Specifications

| | |
|---------------------------------------|--|
| Optical system | CFI optical system |
| Magnification | 40–1500x |
| Illumination | 6V-20W halogen lamp, FL (field lens) unit, lamp changeable by removing the field lens unit |
| Coarse and fine focusing | Coaxial coarse/fine focusing with cross roller guide incorporated, 22mm coarse/fine focusing range, Coarse motion: 37.7mm/rotation, Fine motion: 0.2mm/rotation with 2µm scale increments, Coarse motion torque adjustable |
| Eyepiece tube | E2-TB binocular tube (inclination: 30°, 360° rotatable Siedentopf-type, interpupillary distance: 47–75mm) E2-TF trinocular tube F (2-way, inclination: 30°, 360° rotatable Siedentopf-type, interpupillary distance: 47–75mm) |
| Eyepiece lens (with rubber eye guard) | E1-CFI 10x (F.O.V.: 18mm), CFI E 15x (F.O.V.: 12mm) |
| Condenser | Abbe condenser, NA 1.25 (aperture diaphragm with position guide marking for respective objectives), 33mm-diameter filters attachable (including standard blue filter) |
| Nosepiece | Quadruple click-stop, revolving mechanism with multiple ball bearings, elastic nosepiece grip-ring |
| Dedicated objectives | CFI BE Plan Achromat 4x (NA 0.1/W.D. 25mm), 10x (NA 0.25/W.D. 6.7mm), 20x (NA 0.4/W.D. 3.7mm), 40x (NA 0.65/W.D. 0.6mm), 60x (NA 0.8/W.D. 0.24mm), 100x (NA 1.25/W.D. 0.14mm), DL 10x (NA 0.25/W.D. 6.7), DL 40x (NA 0.65/W.D. 0.6), DL 100x (NA 1.25/W.D. 0.14) |
| Stage | Double-plate rectangular mechanical stage, stage size: 155 (W) x 134 (D)mm, removal slide holder, travel area: 76 (W) x 40 (D)mm, vernier provided |
| Substage | Adjustable vertical condenser movement range: 10mm |
| Optional accessories | Phase contrast attachment (dedicated abbe condenser, sliders, objectives (10x, 40x, 100x), GIF filter, phase centering telescope), object marker, darkfield ring unit, mirror unit, cord hanger, storage case |
| Power consumption | 50W |
| Weight | Approx. 6.5kg |

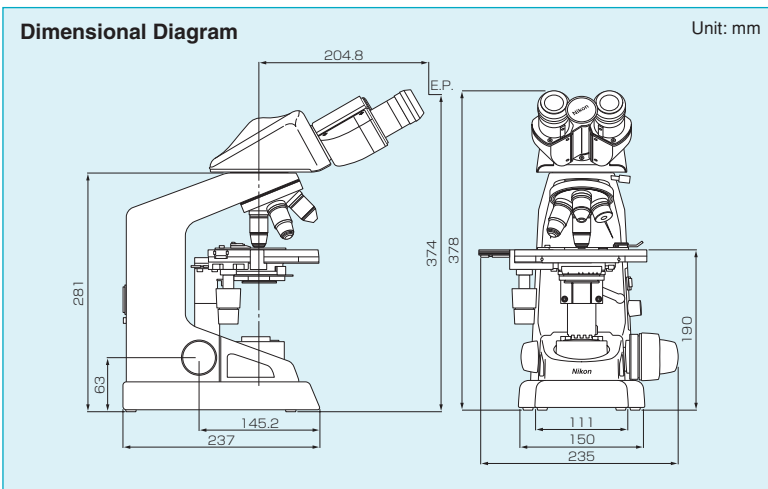

Specifications and equipment are subject to change without any notice or obligation on the part of the manufacturer. November 2006 ©2006 NIKON CORPORATION

WARNING TO ENSURE CORRECT USAGE, READ THE CORRESPONDING MANUALS CAREFULLY BEFORE USING YOUR EQUIPMENT.



NIKON CORPORATION

Parale Mitsui Bldg., 8, Higashida-cho, Kawasaki-ku, Kawasaki, Kanagawa 210-0005, Japan
phone: +81-44-223-2167 fax: +81-44-223-2182
<http://www.nikon-instruments.jp/eng/>

NIKON INSTRUMENTS INC.

1300 Walt Whitman Road, Melville, N.Y. 11747-3064, U.S.A.
phone: +1-631-547-8500; +1-800-52-NIKON (within the U.S.A. only)
fax: +1-631-547-0306
<http://www.nikonusa.com/>

NIKON INSTRUMENTS EUROPE B.V.

P.O. Box 222, 1170 AE Badhoevedorp, The Netherlands
phone: +31-20-44-96-222 fax: +31-20-44-96-298
<http://www.nikon-instruments.com/>

NIKON INSTRUMENTS (SHANGHAI) CO., LTD.

CHINA phone: +86-21-5836-0050 fax: +86-21-5836-0030
(Beijing office) phone: +86-10-5869-2255 fax: +86-10-5869-2277
(Guangzhou office) phone: +86-20-3882-0552 fax: +86-20-3882-0580

NIKON SINGAPORE PTE LTD

SINGAPORE phone: +65-6559-3618 fax: +65-6559-3668

NIKON MALAYSIA SDN. BHD.

MALAYSIA phone: +60-3-78763887 fax: +60-3-78763387

NIKON INSTRUMENTS KOREA CO., LTD.

KOREA phone: +82-2-2186-8410 fax: +82-2-555-4415

NIKON CANADA INC.

CANADA phone: +1-905-625-9910 fax: +1-905-625-0103

NIKON FRANCE S.A.S.

FRANCE phone: +33-1-45-16-45-16 fax: +33-1-45-16-00-33

NIKON GMBH

GERMANY phone: +49-211-9414-0 fax: +49-211-9414-322

NIKON INSTRUMENTS S.p.A.

ITALY phone: +39-55-3009601 fax: +39-55-300993

NIKON AG

SWITZERLAND phone: +41-43-277-2860 fax: +41-43-277-2861

NIKON UK LTD.

UNITED KINGDOM phone: +44-20-8541-4440 fax: +44-20-8541-4584

NIKON GMBH AUSTRIA

AUSTRIA phone: +43-1-972-6111-00 fax: +43-1-972-6111-40

NIKON BELUX

BELGIUM phone: +32-2-705-56-65 fax: +32-2-726-66-45



ISO 9001 Certified
NIKON CORPORATION
Instruments Company



ISO 14001 Certified
NIKON CORPORATION
Yokohama Plant